

5-5 Solving Polynomial Equations

Factor completely. If the polynomial is not factorable, write *prime*.

1. $3ax + 2ay - az + 3bx + 2by - bz$

ANSWER:

$(a + b)(3x + 2y - z)$

2. $2kx + 4mx - 2nx - 3ky - 6my + 3ny$

ANSWER:

$(2x - 3y)(k + 2m - n)$

3. $2x^3 + 5y^3$

ANSWER:

prime

4. $16g^3 + 2h^3$

ANSWER:

$2(2g + h)(4g^2 - 2gh + h^2)$

5. $12qw^3 - 12q^4$

ANSWER:

$12q(w - q)(w^2 + qw + q^2)$

6. $3w^2 + 5x^2 - 6y^2 + 2z^2 + 7a^2 - 9b^2$

ANSWER:

prime

7. $a^6x^2 - b^6x^2$

ANSWER:

$x^2(a - b)(a^2 + ab + b^2)(a + b)(a^2 - ab + b^2)$

8. $x^3y^2 - 8x^3y + 16x^3 + y^5 - 8y^4 + 16y^3$

ANSWER:

$(x + y)(x^2 - xy + y^2)(y - 4)^2$

9. $8c^3 - 125d^3$

ANSWER:

$(2c - 5d)(4c^2 + 10cd + 25d^2)$

10. $6bx + 12cx + 18dx - by - 2cy - 3dy$

ANSWER:

$(6x - y)(b + 2c + 3d)$

Solve each equation.

11. $x^4 - 19x^2 + 48 = 0$

ANSWER:

$4, -4, \pm\sqrt{3}$

12. $x^3 - 64 = 0$

ANSWER:

$4, -2 \pm 2i\sqrt{3}$

13. $x^3 + 27 = 0$

ANSWER:

$-3, \frac{3 \pm 3i\sqrt{3}}{2}$

14. $x^4 - 33x^2 + 200 = 0$

ANSWER:

$5, -5, \pm 2\sqrt{2}$

15. **CCSS PERSEVERANCE** A boardwalk that is x feet wide is built around a rectangular pond. The pond is 30 feet wide and 40 feet long. The combined area of the pond and the boardwalk is 2000 square feet. What is the width of the boardwalk?



ANSWER:

5 ft

Write each expression in quadratic form, if possible.

16. $4x^6 - 2x^3 + 8$

ANSWER:

$(2x^3)^2 - 1(2x^3) + 8$

5-5 Solving Polynomial Equations

17. $25y^6 - 5y^2 + 20$

ANSWER:
not possible

Solve each equation.

18. $x^4 - 6x^2 + 8 = 0$

ANSWER:
 $2, -2, \sqrt{2}, -\sqrt{2}$

19. $y^4 - 18y^2 + 72 = 0$

ANSWER:
 $\sqrt{6}, -\sqrt{6}, 2\sqrt{3}, -2\sqrt{3}$

Factor completely. If the polynomial is not factorable, write prime.

20. $8c^3 - 27d^3$

ANSWER:
 $(2c - 3d)(4c^2 + 6cd + 9d^2)$

21. $64x^4 + xy^3$

ANSWER:
 $x(4x + y)(16x^2 - 4xy + y^2)$

22. $a^8 - a^2b^6$

ANSWER:
 $a^2(a - b)(a^2 + ab + b^2)(a + b)(a^2 - ab + b^2)$

23. $x^6y^3 + y^9$

ANSWER:
 $y^3(x^2 + y^2)(x^4 - x^2y^2 + y^4)$

24. $18x^6 + 5y^6$

ANSWER:
prime

25. $w^3 - 2y^3$

ANSWER:
prime

26. $gx^2 - 3hx^2 - 6y^2 - gy^2 + 6x^2 + 3hy^2$

ANSWER:
 $(x + y)(x - y)(6 + g - 3h)$

27. $12ax^2 - 20cy^2 - 18bx^2 - 10ay^2 + 15by^2 + 24cx^2$

ANSWER:
 $(6x^2 - 5y^2)(2a - 3b + 4c)$

28. $a^3x^2 - 16a^3x + 64a^3 - b^3x^2 + 16b^3x - 64b^3$

ANSWER:
 $(a - b)(a^2 + ab + b^2)(x - 8)^2$

29. $8x^5 - 25y^3 + 80x^4 - x^2y^3 + 200x^3 - 10xy^3$

ANSWER:
 $(2x - y)(4x^2 + 2xy + y^2)(x + 5)^2$

Solve each equation.

30. $x^4 + x^2 - 90 = 0$

ANSWER:
 $3, -3, \pm i\sqrt{10}$

31. $x^4 - 16x^2 - 720 = 0$

ANSWER:
 $6, -6, \pm 2i\sqrt{5}$

32. $x^4 - 7x^2 - 44 = 0$

ANSWER:
 $\pm\sqrt{11}, \pm 2i$

33. $x^4 + 6x^2 - 91 = 0$

ANSWER:
 $\pm\sqrt{7}, \pm i\sqrt{13}$

34. $x^3 + 216 = 0$

ANSWER:
 $3 \pm 3i\sqrt{3}, -6$

5-5 Solving Polynomial Equations

35. $64x^3 + 1 = 0$

ANSWER:

$$-\frac{1}{4}, \frac{1 \pm i\sqrt{3}}{8}$$

Write each expression in quadratic form, if possible.

36. $x^4 + 12x^2 - 8$

ANSWER:

$$(x^2)^2 + 12(x^2) - 8$$

37. $-15x^4 + 18x^2 - 4$

ANSWER:

$$-15(x^2)^2 + 18(x^2) - 4$$

38. $8x^6 + 6x^3 + 7$

ANSWER:

$$2(2x^3)^2 + 3(2x^3) + 7$$

39. $5x^6 - 2x^2 + 8$

ANSWER:

not possible

40. $9x^8 - 21x^4 + 12$

ANSWER:

$$(3x^4)^2 - 7(3x^4) + 12$$

41. $16x^{10} + 2x^5 + 6$

ANSWER:

$$4(2x^5)^2 + 1(2x^5) + 6$$

Solve each equation.

42. $x^4 + 6x^2 + 5 = 0$

ANSWER:

$$\pm i\sqrt{5}, \pm i$$

43. $x^4 - 3x^2 - 10 = 0$

ANSWER:

$$\pm\sqrt{5}, \pm i\sqrt{2}$$

44. $4x^4 - 14x^2 + 12 = 0$

ANSWER:

$$\pm\sqrt{2}, \pm\frac{\sqrt{6}}{2}$$

45. $9x^4 - 27x^2 + 20 = 0$

ANSWER:

$$\pm\frac{2\sqrt{3}}{3}, \pm\frac{\sqrt{15}}{3}$$

46. $4x^4 - 5x^2 - 6 = 0$

ANSWER:

$$\pm i\frac{\sqrt{3}}{2}, \pm\sqrt{2}$$

47. $24x^4 + 14x^2 - 3 = 0$

ANSWER:

$$\pm i\frac{\sqrt{3}}{2}, \pm\frac{\sqrt{6}}{6}$$

48. **ZOOLOGY** A species of animal is introduced to a small island. Suppose the population of the species is represented by $P(t) = -t^4 + 9t^2 + 400$, where t is the time in years. Determine when the population becomes zero.

ANSWER:

5 yr

Factor completely. If the polynomial is not factorable, write prime.

49. $x^4 - 625$

ANSWER:

$$(x^2 + 25)(x + 5)(x - 5)$$

50. $x^6 - 64$

ANSWER:

$$(x + 2)(x^2 - 2x + 4)(x - 2)(x^2 + 2x + 4)$$

51. $x^5 - 16x$

ANSWER:

$$x(x + 2)(x - 2)(x^2 + 4)$$

5-5 Solving Polynomial Equations

52. $8x^5y^2 - 27x^2y^5$

ANSWER:

$$x^2y^2(2x - 3y)(4x^2 + 6xy + 9y^2)$$

53. $15ax - 10bx + 5cx + 12ay - 8by + 4cy + 15az - 10bz + 5cz$

ANSWER:

$$(5x + 4y + 5z)(3a - 2b + c)$$

54. $6a^2x^2 - 24b^2x^2 + 18c^2x^2 - 5a^2y^3 + 20b^2y^3 - 15c^2y^3 + 2a^2z^2 - 8b^2z^2 + 6c^2z^2$

ANSWER:

$$(6x^2 - 5y^3 + 2z^2)(a^2 - 4b^2 + 3c^2)$$

55. $6x^5 - 11x^4 - 10x^3 - 54x^3 + 99x^2 + 90x$

ANSWER:

$$x(x + 3)(x - 3)(3x + 2)(2x - 5)$$

56. $20x^6 - 7x^5 - 6x^4 - 500x^4 + 175x^3 + 150x^2$

ANSWER:

$$x^2(x + 5)(x - 5)(4x - 3)(5x + 2)$$

57. **GEOMETRY** The volume of the figure at the right is 440 cubic centimeters. Find the value of x and the length, height, and width.

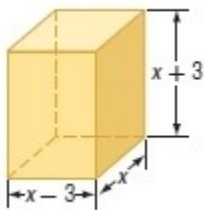

ANSWER:

$$x = 8; 8, 11, 5$$

Solve each equation.

58. $8x^4 + 10x^2 - 3 = 0$

ANSWER:

$$\pm \frac{1}{2}, \pm i \frac{\sqrt{6}}{2}$$

59. $6x^4 - 5x^2 - 4 = 0$

ANSWER:

$$\pm \frac{2\sqrt{3}}{3}, \pm i \frac{\sqrt{2}}{2}$$

60. $20x^4 - 53x^2 + 18 = 0$

ANSWER:

$$\pm \frac{3}{2}, \pm \frac{\sqrt{10}}{5}$$

61. $18x^4 + 43x^2 - 5 = 0$

ANSWER:

$$\pm \frac{1}{3}, \pm i \frac{\sqrt{10}}{2}$$

62. $8x^4 - 18x^2 + 4 = 0$

ANSWER:

$$\pm \sqrt{2}, \pm \frac{1}{2}$$

63. $3x^4 - 22x^2 - 45 = 0$

ANSWER:

$$\pm 3, \pm i \frac{\sqrt{15}}{3}$$

64. $x^6 + 7x^3 - 8 = 0$

ANSWER:

$$1, -2, \frac{-1 \pm i\sqrt{3}}{2}, 1 \pm i\sqrt{3}$$

65. $x^6 - 26x^3 - 27 = 0$

ANSWER:

$$-1, 3, \frac{-3 \pm 3i\sqrt{3}}{2}, \frac{1 \pm i\sqrt{3}}{2}$$

66. $8x^6 + 999x^3 = 125$

ANSWER:

$$-5, \frac{1}{2}, \frac{-1 \pm i\sqrt{3}}{2}, \frac{5 \pm 5i\sqrt{3}}{2}$$

5-5 Solving Polynomial Equations

67. $4x^4 - 4x^2 - x^2 + 1 = 0$

ANSWER:

$$\pm \frac{1}{2}, \pm 1$$

68. $x^6 - 9x^4 - x^2 + 9 = 0$

ANSWER:

$$\pm i, \pm 1, \pm 3$$

69. $x^4 + 8x^2 + 15 = 0$

ANSWER:

$$\pm i\sqrt{3}, \pm i\sqrt{5}$$

70. **CCSS SENSE-MAKING** A rectangular prism with dimensions $x - 2$, $x - 4$, and $x - 6$ has a volume equal to $40x$ cubic units.

- Write out a polynomial equation using the formula for volume.
- Use factoring to solve for x .
- Are any values for x unreasonable? Explain.
- What are the dimensions of the prism?

ANSWER:

- $x^3 - 12x^2 + 44x - 48 = 40x$
- 12, $\pm 2i$
- Sample answer: $\pm 2i$ because they are imaginary numbers
- 6, 8 and 10

71. **POOL DESIGN** Andrea wants to build a pool following the diagram at the right. The pool will be surrounded by a sidewalk of a constant width.

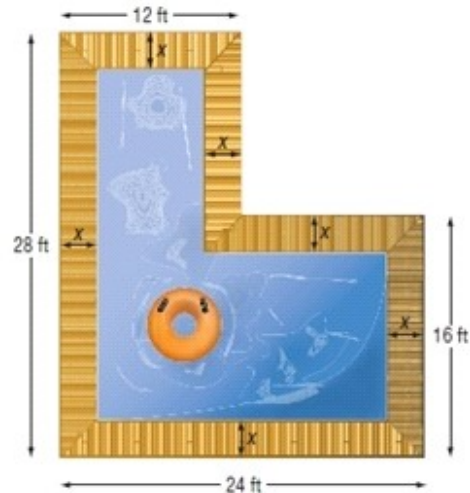

- If the total area of the pool itself is to be 336 ft^2 , what is x ?
- If the value of x were doubled, what would be the new area of the pool?
- If the value of x were halved, what would be the new area of the pool?

ANSWER:

- 2 ft
- 176 ft^2
- 428 ft^2

5-5 Solving Polynomial Equations

72. **BIOLOGY** During an experiment, the number of cells of a virus can be modeled by $P(t) = -0.012t^3 - 0.24t^2 + 6.3t + 8000$, where t is the time in hours and P is the number of cells. Jack wants to determine the times at which there are 8000 cells.
- Solve for t by factoring.
 - What method did you use to factor?
 - Which values for t are reasonable and which are unreasonable? Explain.
 - Graph the function for $0 \leq t \leq 20$ using your calculator.

ANSWER:

- 15, 0, -35
- Sample answer: Subtract 8000 from each side. Then multiply each side by 1000 to estimate the decimal. Factor out 12t, then factor the remaining trinomial.
- 15 and 0 are reasonable, and -35 is unreasonable because time cannot be negative.
-

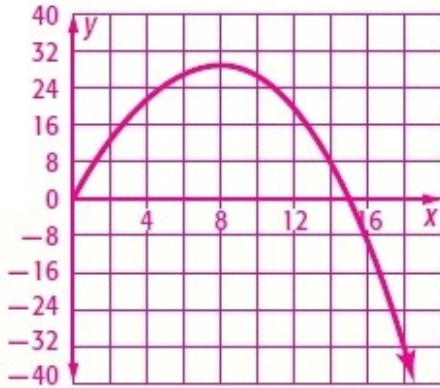

73. **HOME BUILDING** Alicia's parents want their basement home theater designed according to the diagram.

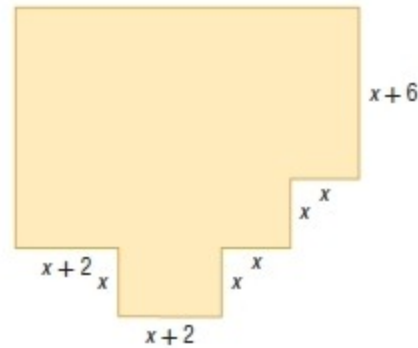

- Write a function in terms of x for the area of the basement.
- If the basement is to be 1366 square feet, what is x ?

ANSWER:

- $f(x) = 8x^2 + 34x + 24$
- 11 ft

74. **BIOLOGY** A population of parasites in an experiment can be modeled by $f(t) = t^3 + 5t^2 - 4t - 20$, where t is the time in days.
- Use factoring by grouping to determine the values of t for which $f(t) = 0$.
 - At what times does the population reach zero?
 - Are any of the values of t unreasonable? Explain.

ANSWER:

- 2, -2, -5
- 2 days, -2 days, and -5 days
- 2 and -5 are unreasonable because time cannot be negative.

Factor completely. If the polynomial is not factorable, write prime.

75. $x^6 - 4x^4 - 8x^4 + 32x^2 + 16x^2 - 64$

ANSWER:

$$(x + 2)^3(x - 2)^3$$

76. $y^9 - y^6 - 2y^6 + 2y^3 + y^3 - 1$

ANSWER:

$$(y - 1)^3(y^2 + y + 1)^3$$

5-5 Solving Polynomial Equations

77. $x^6 - 3x^4y^2 + 3x^2y^4 - y^6$

ANSWER:

$$(x+y)^3(x-y)^3$$

78. **CCSS SENSE-MAKING** Fredo's corral, an enclosure for livestock, is currently 32 feet by 40 feet. He wants to enlarge the area to 4.5 times its current area by increasing the length and width by the same amount.

- Draw a diagram to represent the situation.
- Write a polynomial equation for the area of the new corral. Then solve the equation by factoring.
- Graph the function.
- Which solution is irrelevant? Explain.

ANSWER:

a.

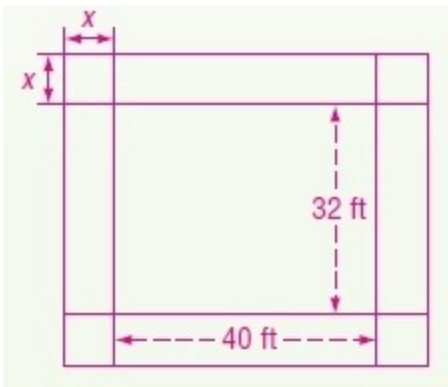

b. $4x^2 + 144x + 1280 = 5760$; $x = -56$ or 20

c.

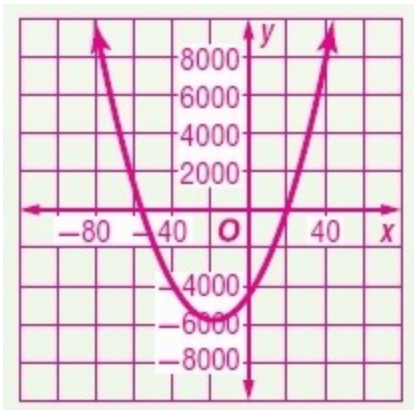

- d. -56 is irrelevant because length cannot be negative.

79. **CHALLENGE** Factor $36x^{2n} + 12x^n + 1$.

ANSWER:

$$(6x^n + 1)^2$$

80. **CHALLENGE** Solve $6x - 11\sqrt{3x} + 12 = 0$.

ANSWER:

$$\frac{16}{3}, \frac{3}{4}$$

81. **REASONING** Find a counterexample to the statement $a^2 + b^2 = (a+b)^2$.

ANSWER:

Sample answer: $a = 1$, $b = -1$

82. **OPEN ENDED** The cubic form of an equation is $ax^3 + bx^2 + cx + d = 0$. Write an equation with degree 6 that can be written in *cubic* form

ANSWER:

Sample answer: $12x^6 + 6x^4 + 8x^2 + 4 = 12(x^2)^3 + 6(x^2)^2 + 8(x^2) + 4$

83. **WRITING IN MATH** Explain how the graph of a polynomial function can help you factor the polynomial.

ANSWER:

Sample answer: The factors can be determined by the x -intercepts of the graph. An x -intercept of 5 represents a factor of $(x - 5)$.

84. **SHORT RESPONSE** Tiles numbered from 1 to 6 are placed in a bag and are drawn to determine which of six tasks will be assigned to six people. What is the probability that the tiles numbered 5 and 6 are the last two drawn?

ANSWER:

$$\frac{1}{15}$$

5-5 Solving Polynomial Equations

85. **STATISTICS** Which of the following represents a negative correlation?

A.



B.

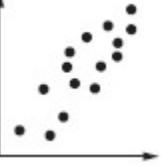

C.

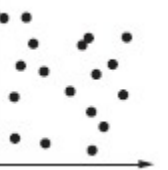

D.

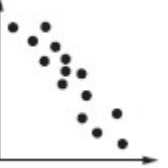

ANSWER:

D

86. Which of the following most accurately describes the translation of the graph $y = (x + 4)^2 - 3$ to the graph of $y = (x - 1)^2 + 3$?

F down 1 and to the right 3

G down 6 and to the left 5

H up 1 and to the left 3

J up 6 and to the right 5

ANSWER:

J

87. **SAT/ACT** The positive difference between k and $\frac{1}{12}$ is the same as the positive difference between

$\frac{1}{3}$ and $\frac{1}{5}$. Which of the following is the value of k ?

A. $\frac{1}{60}$

B. $\frac{1}{20}$

C. $\frac{1}{15}$

D. $\frac{13}{60}$

E. $\frac{37}{60}$

ANSWER:

D

Graph each polynomial function. Estimate the x -coordinates at which the relative maxima and relative minima occur.

88. $f(x) = 2x^3 - 4x^2 + x + 8$

ANSWER:

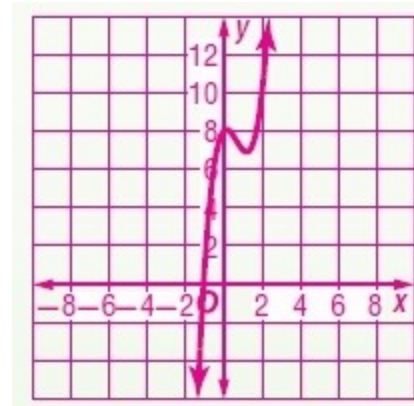

rel maximum at $x \approx 0.1$; rel minimum at $x \approx 1.2$;

5-5 Solving Polynomial Equations

89. $f(x) = -3x^3 + 6x^2 + 2x - 1$

ANSWER:

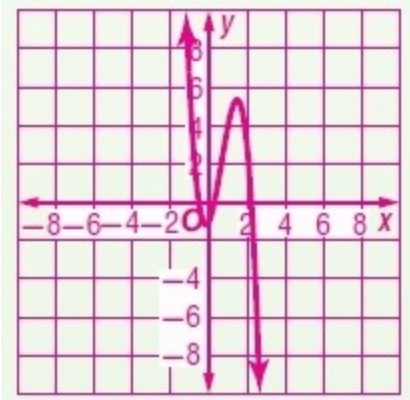

rel maximum at $x \approx 1.5$, rel minimum at $x \approx 0.1$;

90. $f(x) = -x^3 + 3x^2 + 4x - 6$

ANSWER:

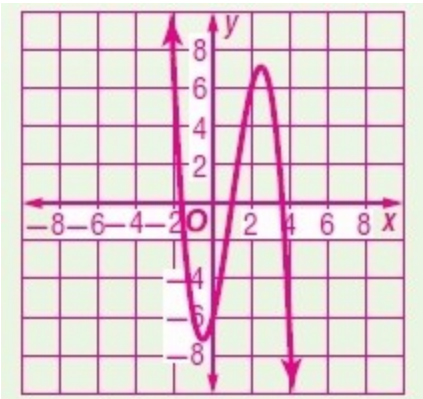

rel maximum at $x \approx 2.5$, rel minimum at $x \approx -0.5$;

State the degree and leading coefficient of each polynomial in one variable. If it is not a polynomial in one variable, explain why.

91. $f(x) = 4x^3 - 6x^2 + 5x^4 - 8x$

ANSWER:

degree = 4; leading coefficient = 5

92. $f(x) = -2x^5 + 5x^4 + 3x^2 + 9$

ANSWER:

degree = 5; leading coefficient = -2

93. $f(x) = -x^4 - 3x^3 + 2x^6 - x^7$

ANSWER:

degree = 7; leading coefficient = -1

94. **ELECTRICITY** The impedance in one part of a series circuit is $3 + 4j$ ohms, and the impedance in another part of the circuit is $2 - 6j$. Add these complex numbers to find the total impedance of the circuit.

ANSWER:

$$5 - 2j$$

95. **SKIING** All 28 members of a ski club went on a trip. The club paid a total of \$478 for the equipment. How many skis and snowboards did they rent?



ANSWER:

18 skis and 10 snowboards

96. **GEOMETRY** The sides of an angle are parts of two lines whose equations are $2y + 3x = -7$ and $3y - 2x = 9$. The angle's vertex is the point where the two sides meet. Find the coordinates of the vertex of the angle.

ANSWER:

$$(-3, 1)$$

Divide.

97. $(x^2 + 6x - 2) \div (x + 4)$

ANSWER:

$$x + 2 - \frac{10}{x + 4}$$

98. $(2x^2 + 8x - 10) \div (2x + 1)$

ANSWER:

$$x + \frac{7}{2} - \frac{27}{4x + 2} \text{ or } x + 3.5 - \frac{13.5}{2x + 1}$$

5-5 Solving Polynomial Equations

99. $(8x^3 + 4x^2 + 6) \div (x + 2)$

ANSWER:

$$8x^2 - 12x + 24 - \frac{42}{x+2}$$